

**CLEAN ENERGY FROM THE SUN  
TO HEAT YOUR HOME OR OFFICE**



**FEATURES**

**Simple and Efficient**  
**No Freezing**  
**No Chemicals**  
**Low Maintenance**  
**One Moving Part**  
**Over 25,000 installed**  
**Easy Installation**  
**Five Year Warranty**  
**4' x 8' and 4' x 12'**

**DISTRIBUTED BY**

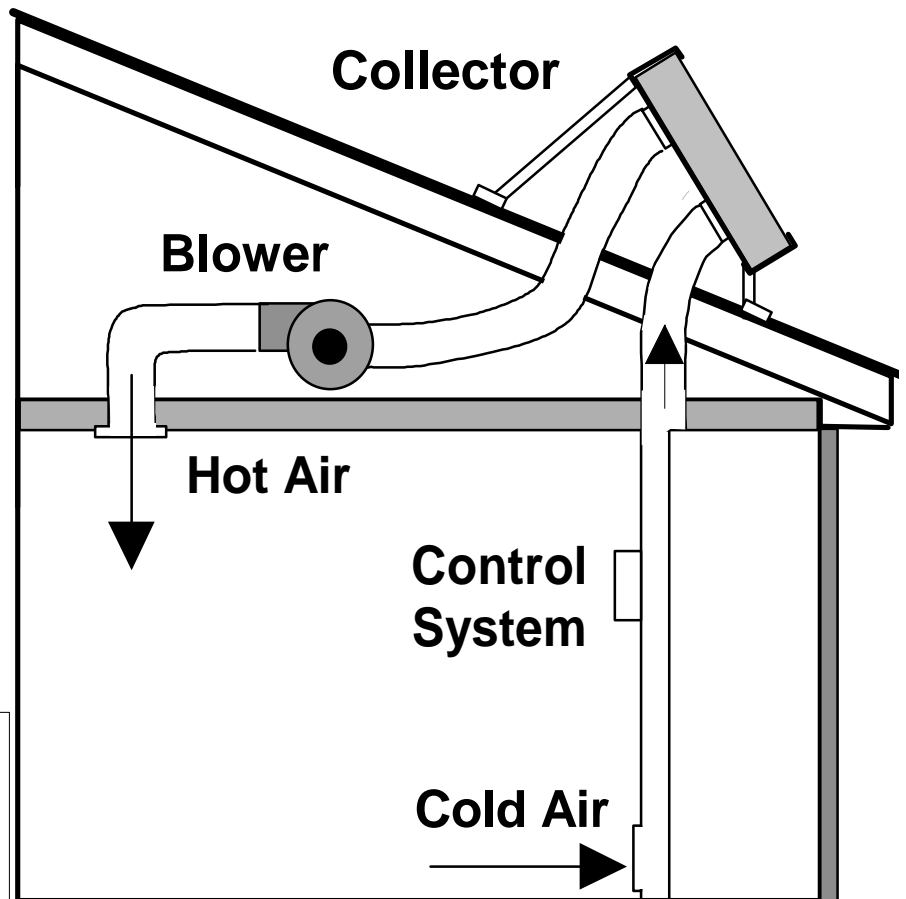

**Good Ideas that Pay for Themselves**

# SUN AIRE AIR COLLECTOR SPECIFICATIONS

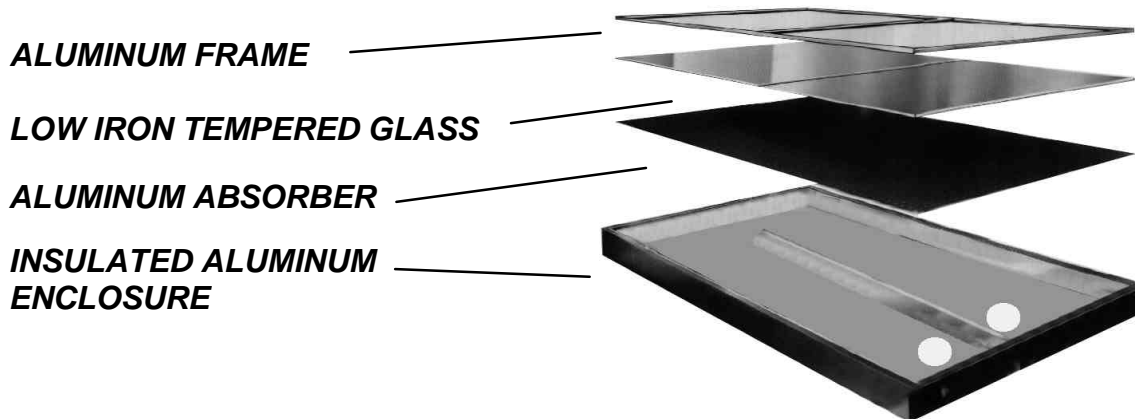
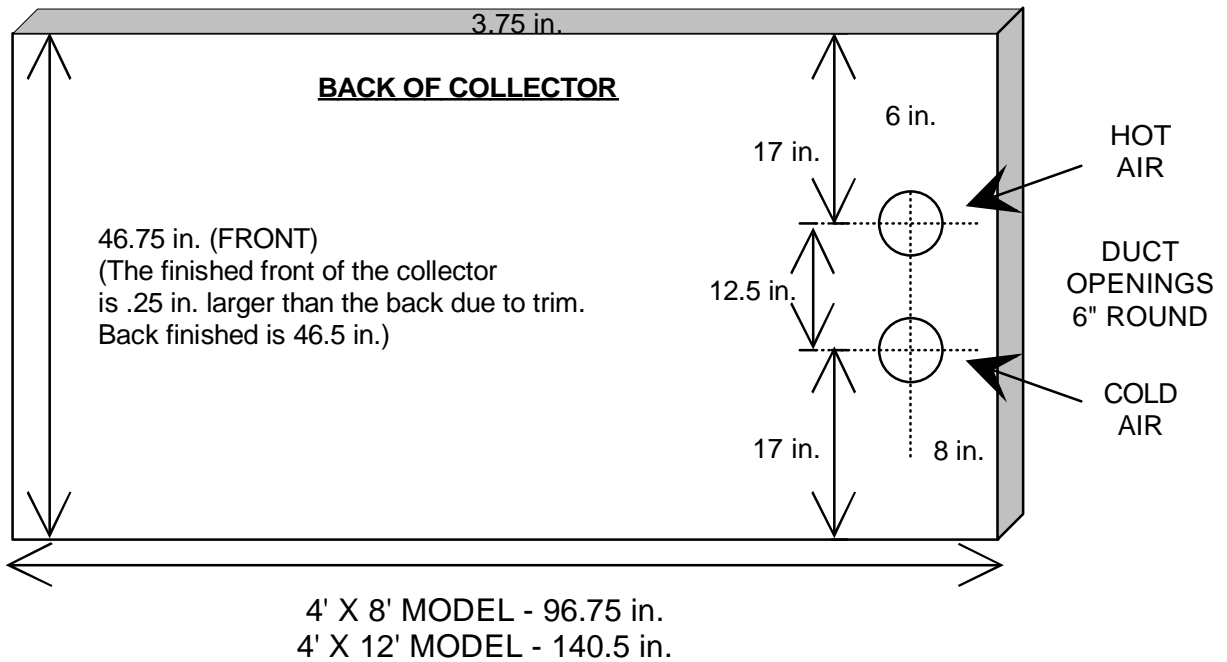

ENCLOSURE - .024 BROWN ALUMINUM  
 ABSORBER - .019 BLACK ALUMINUM  
 INSULATION - R-8 ISOCYANURATE BACK & SIDES  
 AIR FLOW - DUAL PASS BEHIND ABSORBER  
 GLAZING - LOW IRON TEMPERED GLASS  
 WEIGHT - 32 SQ.FT. - 98 LBS. 48 SQ.FT. - 145 LBS.  
 SHIPPING WEIGHT (CRATED) - 190 LBS. - 240 LBS.  
 BLOWER - 362 CFM, 488 CFM FOR TWO COLLECTORS  
 DUCT - 6" INSULATED FLEX  
 TILT - LOCAL LATITUDE + 15 DEGREES  
 MAXIMUM COLLECTORS RECOMENDED PER BLOWER - 4

