

# GL-235-LV GL-235-LV-HV



## Goldline Pool & Spa Control

### Description

The GL-235-LV and GL-235-LV-HV are differential temperature controls for solar heating of pools, spas, and hot tubs. These models provide differential temperature control with an adjustable, calibrated water temperature high limit. Automatic nocturnal cooling (for pools that overheat in hot climates) and recirculate freeze protection functions can be enabled/disabled via internal jumpers.

Input power can be either 115 or 240 VAC. The output controls a 24VAC automatic valve actuator. For older systems with 12VAC valves, an internal jumper can be moved to select 12 VAC output operation. The GL-235-LV-HV has one low voltage output for controlling a single valve and a second high voltage output for controlling a filter pump or booster pump.

### Specifications

**Power:** 105-130VAC, .5A 50/60Hz.  
Or  
195-250VAC, .3A 50/60Hz

**Output:** Selectable low voltage 24VAC, 20VA, .85A or 12VAC, 20VA, 1.7A

**GL-235-LV-HV only:**  
SPST-NO isolated contact  
115VAC 1HP  
240VAC 2HP

**Sensors:** 2 required (thermistor, 10K @ 25C/77°F).

**On differential:** 4°F

**Off differential:** 1.5°F

**High Limit:** 70-104°F calibrated scale

**Recirculate freeze:** On at <40°F, off at > 42°F

**Nocturnal cooling:** On when collector 8°F less than pool and pool hotter than limit, off when collector 3°F less than pool or pool cooler than high limit

# Installation

## Mounting

The GL-235 is designed for outdoor use. Mount the box vertically with the knockouts facing downward. For safety, the GL-235 must be a minimum of 5 feet (horizontally) from the pool or spa.

## Power input

Turn off power at circuit breaker before wiring. Remove the internal panel to expose the wiring connections. Either 115VAC or 240VAC can be used. Refer to the input wiring diagram (Figure 1) below.

## Grounding

Refer to NEC and local codes for specific grounding requirements. In general, a separate ground conductor must be run to the ground terminal on the pool service panel.

## Output wiring to solar valve

The GL-235-LV and GL-235-LV-HV control a single valve. In most applications this is the solar valve, which diverts water through the collector panels or through the normal pool loop depending on conditions.

All controls are shipped with the output voltage set to the industry standard 24VAC. To use the GL-235 with older 12VAC valves, move jumper J4, located on the right side of the circuit board.

The GL-235-LV-HV provides two different types of connections to the pool/spa actuators. For older actuators with no wire end connector, a 3 position terminal block is used. Connect the wires to the proper terminal block according to the color code shown in Figure 4. If the valve operates opposite to the way it is supposed to, reverse the red and white wires. Be careful not to short the valve output wiring. The GL-235 is fused and shorting the output will require replacing the fuse.

For newer Goldline, Jandy, and Compool actuators (with wire end connectors), two 3-pin connectors are supplied. (The GL-235-LV model, supplied as part of the GLC Goldline Combo, has two 3-pin connectors only.) Plug the actuator into one of the two 3 pin connectors as shown in figure 2 or 3. If the valve operates opposite to the way it is supposed to, disconnect and plug into the other connector.

## Sensor Mounting and Wiring

Most installations use a PC sensor to measure the pool temperature and another PC sensor to measure the solar temperature. Alternatively, an SC-¼ sensor can be screwed into the pump strainer basket to measure the pool temperature.

*Pool Sensor:* Drill a 3/8" (or 5/16") hole in the PVC pipe. Remove burrs around the hole. Check that the O-ring is seated on the PC sensor and then insert sensor into pipe. Tighten hose clamp over the sensor to make a seal—DO NOT OVERTIGHTEN.

*Solar Sensor:* Use a screw or silicon adhesive to attach the sensor near the solar collector array. The sensor does not have to be attached to the collectors. It is only important that the sensor be exposed to the same sunlight as the collectors. Additionally, the underside of the sensing element may be covered with silicon to minimize wind cooling.

Other 10K ohm Goldline sensors may be substituted. Wire should be twisted pair 20AWG. Sensor wiring run outdoors must be rated for outdoor use and ensure that the wire connections are protected from the weather. For long runs or runs near other electrical wiring use shielded cable (Belden 8428 for outdoor use). Ground the shields to the GL-35/LV ground screw.

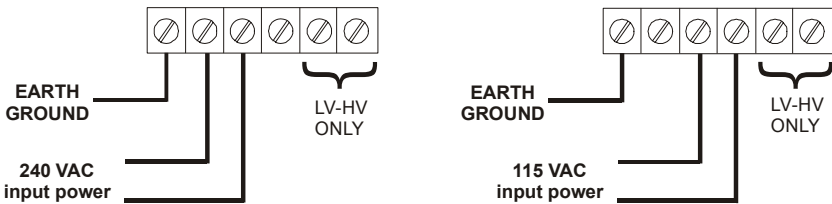

Figure 1

# Installation (continued)

## Freeze Protection

If you are relying on the collectors naturally draining to provide freeze protection, it is very important that you use a non-positive seal valve or drill a hole in the diverter of a positive seal valve to allow the collectors to drain. Alternatively, the GL-235 control can provide recirculate freeze protection. If enabled, when the GL-235 senses a freeze condition at the collector sensor, it will allow circulation of relatively warm water from the pool to the collector panels.

The GL-235 will allow recirculation when the collector temperature falls below 40°F and will stop circulation when the collector temperature rises above 42°F. While this type of freeze protection has proven to be adequate in relatively mild climates, it is extremely important that the sensors be properly placed and that the homeowner realize that the system is unprotected in the event of a power failure. Recirculate freeze protection is NOT recommended in climates where freezing temperatures are common or last for extended periods.

Goldline strongly recommends the use of GC-1 or GC-2 freeze snap switches if freeze protection is being utilized. Snap switches should be wired in series with the collector sensor. Placement of the snap switches at the coldest point of the collector array and exposed plumbing will help assure that freeze protection starts early enough to protect the system.

The GL-235 is shipped from the factory with recirculate freeze protection disabled (the jumper is present but installed on one pin only). To activate recirculate freeze protection, install the jumper across both pins marked "RECIRC", located near the top right of the main circuit board.

If recirculate freeze protection is to be used on a GL-235, either:

- The filter pump must be set for continuous operation

*or*

- The GL235-LV-HV High Voltage Output must be wired for Timer Override function.

## Nocturnal Cooling

The GL-235 has nocturnal cooling logic, which can be enabled/disabled via a jumper on the main circuit board. During nighttime hours, when enabled, the GL-235 will circulate relatively warmer water from the pool to the collector panels, thus cooling the pool over time. The GL-235 will circulate water when the collector temperature AND the pool temperature is hotter than the high limit setting. Circulation will stop when the collector temperature is 3°F less than the pool temperature OR the pool temperature is cooler than the high limit setting. The GL-235 is shipped from the factory with nocturnal cooling disabled (the jumper is present but installed on one pin only). To activate nocturnal cooling, install the jumper provided onto the two pins marked "COOLING" located near the top right of the main circuit board.

If nocturnal cooling is to be used, either:

- The filter pump must be set for continuous operation

*or*

- The GL-235-LV-HV High Voltage Output must be wired for Timer Override function.

## Booster Pump (model GL-235-LV-HV only)

The GL-235 can control a high voltage booster pump in addition to the normal low voltage solar valve. Note the high voltage relay contacts are isolated so that the booster pump can be run on a separate circuit, as required by many local codes. The GL-235 will turn the booster pump and solar valve on/off simultaneously.

## Timer Override (model GL-235-LV-HV only)

The GL-235 can also be used to override the filter pump timer. This is very important if recirculate freeze protection or nocturnal cooling functions are being used. Also, this function can be used on systems where the system should operate whenever solar heat is available, regardless of the timer settings.

## Operation

For normal operation place the switch in the “AUTO” position and adjust the desired pool/spa temperature setting. The “Power” LED indicator should always be on. (NOTE: During initial power up, the “POWER” indicator will blink for approximately 10 seconds while it stabilizes temperature readings). The “Heating” LED indicator will show when the system is collecting solar heat. If the nocturnal cooling function is enabled inside the GL-235, the “Cooling” LED indicator will show when the system is dissipating excess heat.

In the “AUTO” position, the GL-235 will heat the pool or spa (rotate valve to solar loop) when the collector (solar) sensor temperature is higher than the pool/spa sensor temperature by 4°F or more AND the pool/spa temperature is less than the high limit setting. The GL-235 will stop

heating (return valve to pool loop) when the two sensor temperatures get to within 1.5°F OR the pool/spa sensor is above the high limit setting.

To test the system, move the switch to “ON” and verify that both the “Heating” and “Cooling” indicators light and that the valve(s) are in the solar loop position. Move the switch to “OFF” and verify that all indicators except “Power” are off. The valve(s) should be in the normal recirculating loop position. If the valve(s) positions are working in reverse, follow the instructions in section marked “**Output wiring to solar valve**” to correct. If recirculate freeze protection is being used, do NOT leave the switch in the “OFF” position during cold weather. Also note that the switch does NOT turn power off to the GL-235.

## Troubleshooting

### No Power Indicator

- Check main power circuit breakers.
- Check fuse

### Fuse Replacement

The GL-235 is protected by a fuse located on the left upper side of the main circuit board. Replace the fuse with a 2A, type 3AG SLO-BLO fuse, readily available in most electrical or electronics stores.

### If “Heating” is always on

Disable recirculate freeze protection if enabled. Check that the switch is in the “AUTO” position. Next verify that the control circuitry is operating properly by disconnecting the solar sensor from the terminal block. The “Heating” LED should go off and the “CHECK SENSOR” LED should begin to blink. If “Heating” remains on, there is an internal circuit failure and the GL-235LV will have to be returned for repair.

### If “Heating” never comes on

Verify that the switch is in the “AUTO” position. Disconnect the pool sensor from the terminal block and verify that the “CHECK SENSOR” LED turns on. If the “CHECK SENSOR” LED does not turn on, there is an internal failure and the GL-235 will have to be returned for repair. Reconnect the pool sensor and verify that the “Check Sensor” LED turns off. Next, disconnect the “solar” sensor from the terminal block and verify that the “CHECK SENSOR” LED begins to blink. If the “CHECK

SENSOR” LED does not begin to blink, there is an internal failure and the GL-235 will have to be returned for repair.

### “CHECK SENSOR” indicator on

If the “CHECK SENSOR” indicator is on and NOT blinking, there may be a possible open circuit or short circuit with the pool sensor. Using a voltmeter, measure the voltage across the terminals of the pool sensor as indicated in figure 5. If the voltage is close to zero volts, the sensor has a short to ground. Remove the sensor from the terminal block and measure the voltage across the pool terminals again. If the voltage is still close to zero volts, there is an internal short and the unit must be returned for repair. If the voltage is close to five volts, the pool sensor itself may be at fault.

With the sensor disconnected from the unit, measure the resistance of the sensor using an ohmmeter. At room temperature (25°C/77°F) the sensor should measure approximately 10K ohms (10,000 ohms ± 1%). For other resistance measurements at different temperatures, consult the table at back of manual. If the sensor is not returning the correct value, it is defective and will need to be replaced. If the sensor is returning approximately the correct value, reconnect it to the terminals marked “POOL SENSOR”. If the “CHECK SENSOR” indicator remains on, the unit is defective and needs to be replaced.

## Troubleshooting (continued)

### **“CHECK SENSOR” indicator blinking**

If the “CHECK SENSOR” indicator is blinking, there may be a possible open circuit or short circuit with the solar sensor. Using a voltmeter, measure the voltage across the terminals of the solar sensor as indicated in figure 6. If the voltage is close to zero volts, the sensor has a short to ground. Remove the sensor from the terminal block and measure the voltage across the solar terminals again. If the voltage is still close to zero volts, there is an internal short and the unit must be returned for repair. If the voltage is close to five volts, the solar sensor itself may be at fault.

With the sensor disconnected from the unit, measure the resistance of the sensor using an ohmmeter. At room temperature (25°C/77°F)

the sensor should measure approximately 10K ohms (10,000 ohms  $\pm$  1%). For other resistance measurements at different temperatures, consult the table at back of manual. If the sensor is not returning the correct value, it is defective and will need to be replaced. If the sensor is returning approximately the correct value, reconnect it to the terminals marked “SOLAR SENSOR”. If the “CHECK SENSOR” indicator remains on, the unit is defective and needs to be replaced.

### **If FREEZE PROTECTION is enabled:**

When a sensor is disconnected from the unit and freeze protection has been enabled, the SENSOR FAULT light will NOT activate. The GL-235 will recognize this as a freeze condition and activate freeze protection.

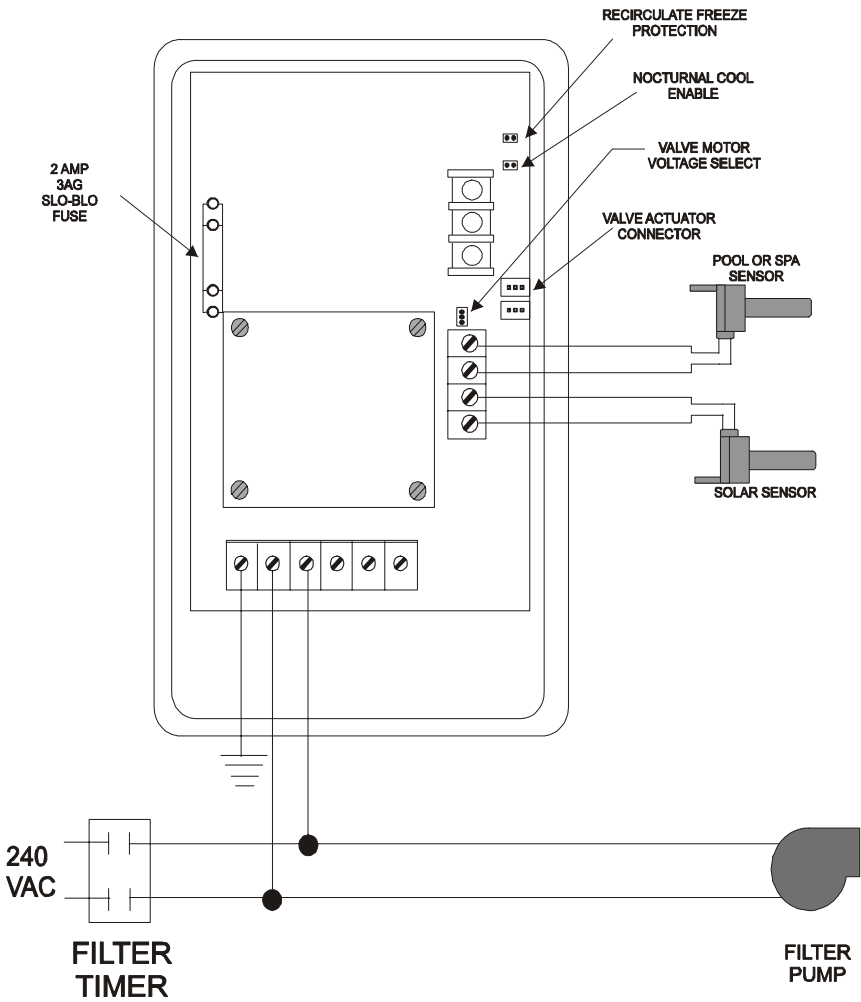

Basic Installation of GL-235-LV  
Figure 2

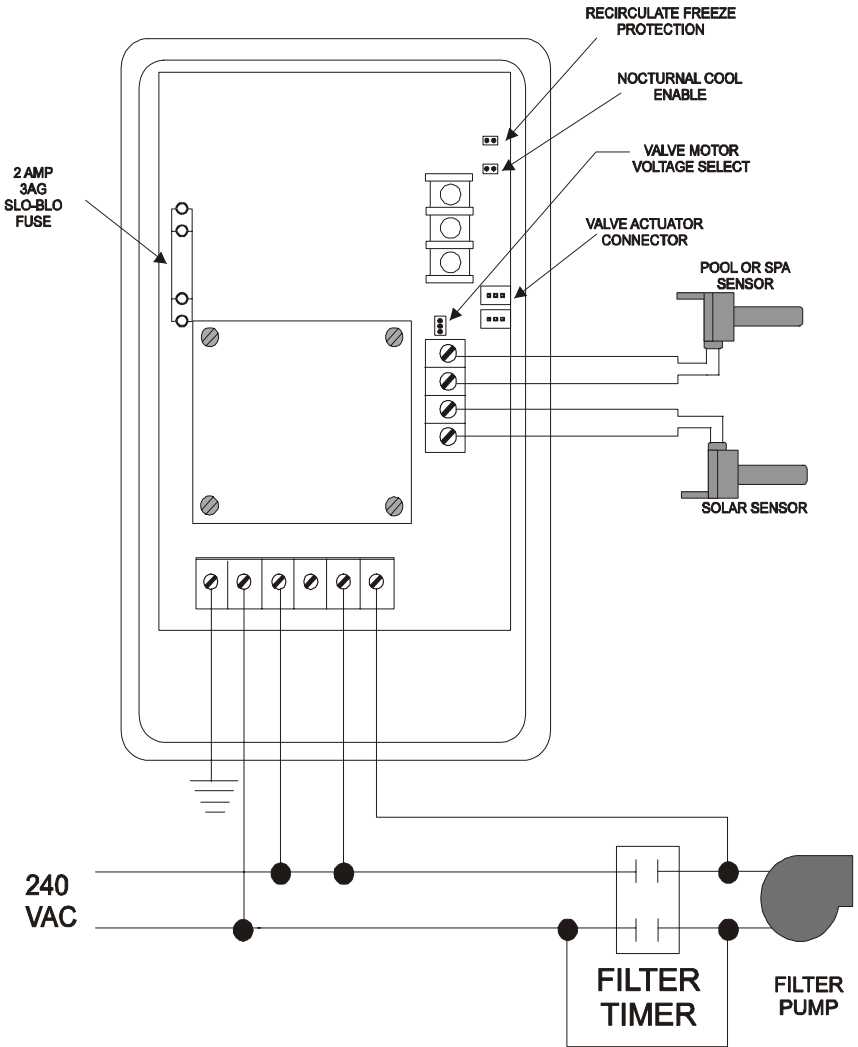

GL-235-LV-HV with High Voltage Output used for Timer Override  
Figure 3

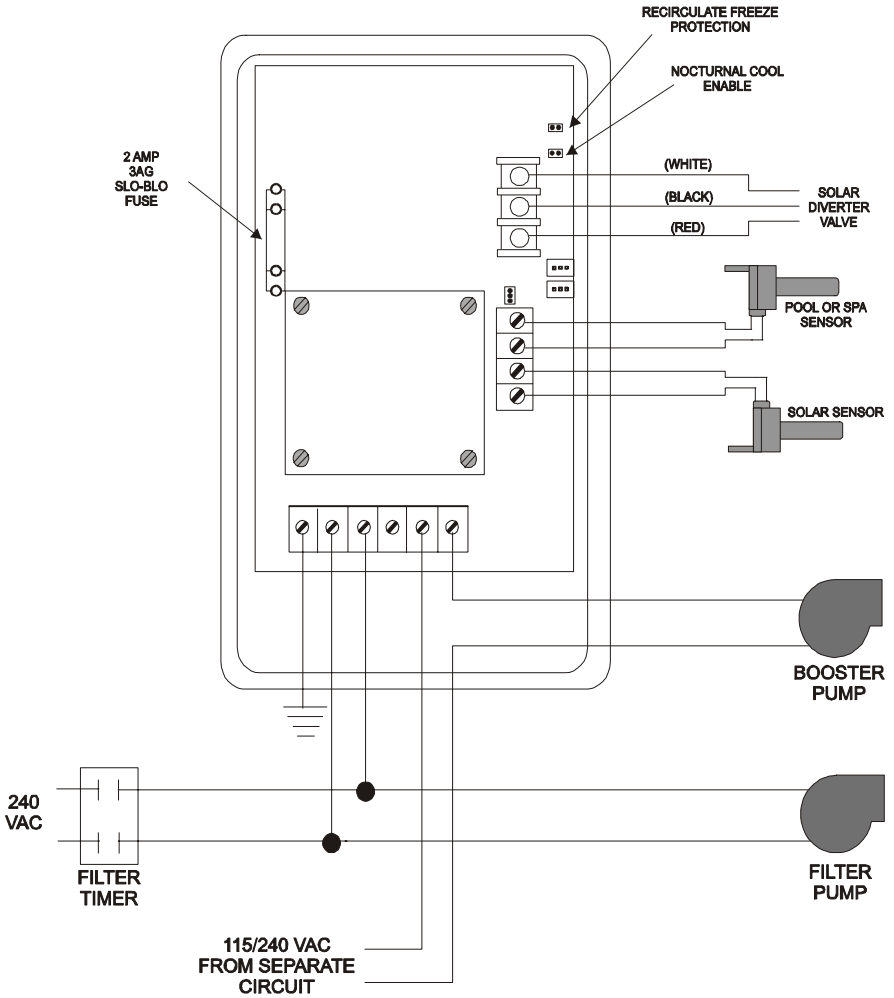

GL-235-LV-HV with High Voltage Output used for Booster Pump  
Figure 4

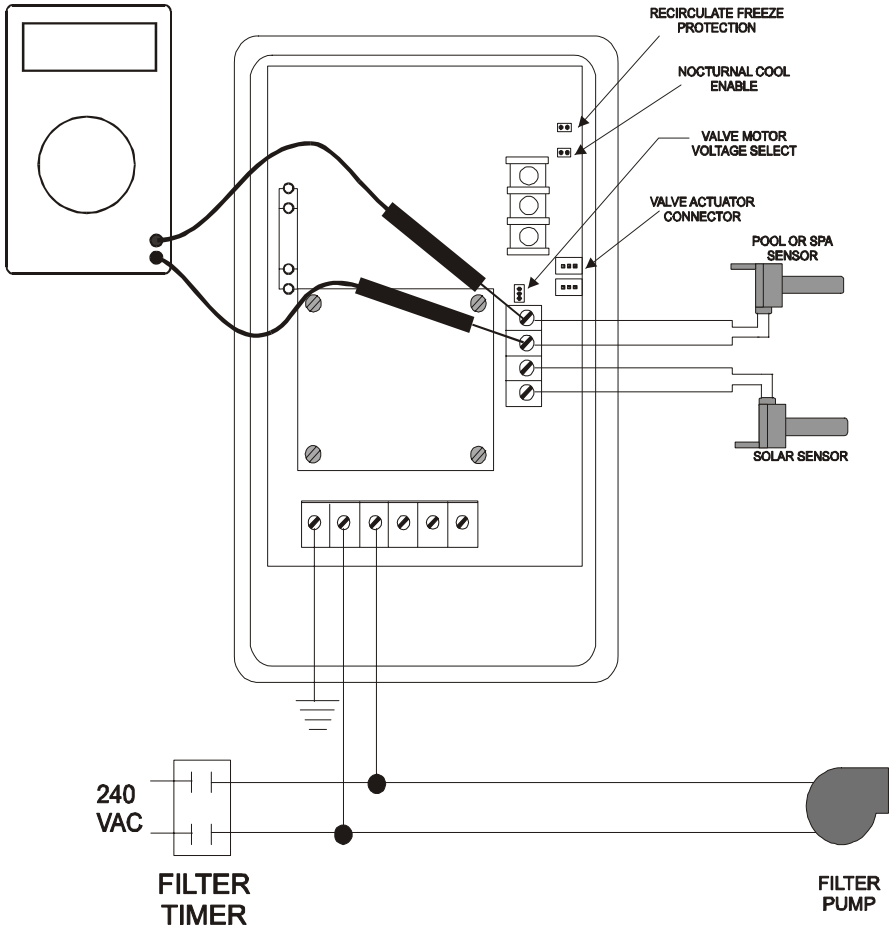

Measuring Voltage of Pool Sensor  
Figure 5

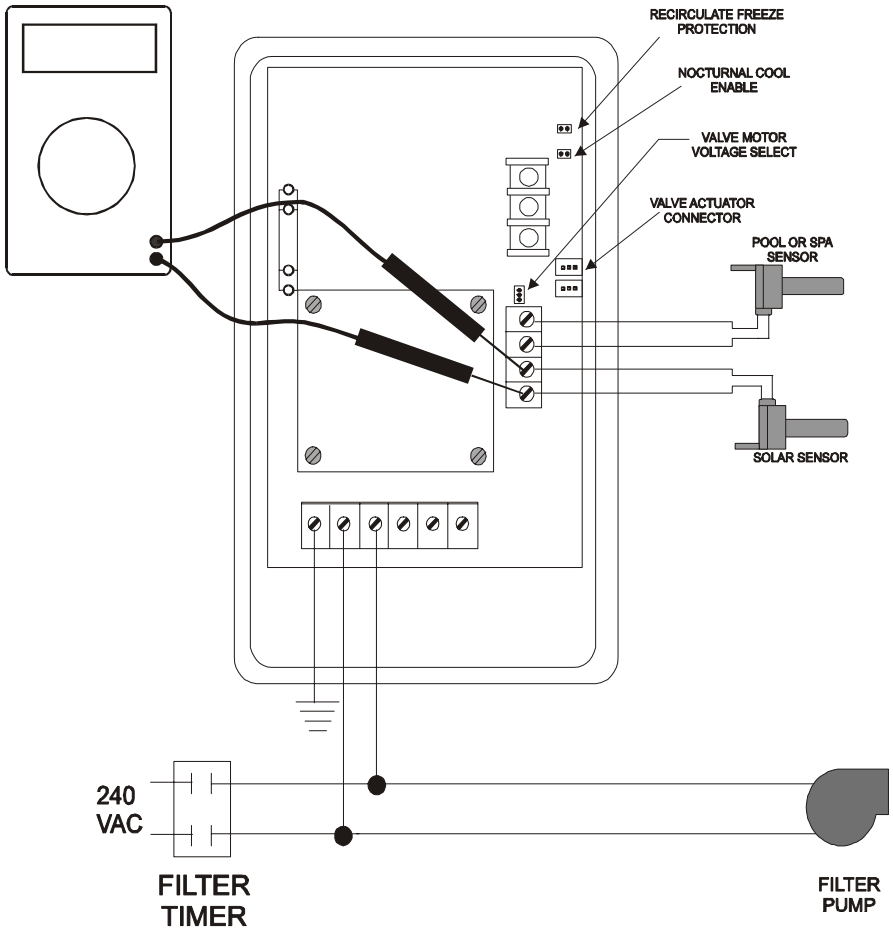

Measuring Voltage of Solar Sensor  
Figure 6

# Technical Assistance

For help in installing, operating, or troubleshooting this control, you may call for technical assistance at 800-343-0826. Goldline Controls technicians are available from 8:00AM

to 5:00PM Eastern Time, Monday through Friday. You may call at other times and leave a message, and a technician will call you back as soon as possible.

# Temperature/Resistance/Voltage

All Goldline controls use 10K thermistor sensors. When disconnected from the control the sensor will read 10K ohms at 25°C/77°F. Refer to the chart below for the resistance at other temperatures. For a given temperature, the resistance reading should be accurate to ±1%. For a given resistance reading, the temperature read-

ing should be accurate to ±0.5°F. Voltage measurements should be accurate to ±2%. Ohm measurements made with sensor disconnected from unit. Voltage measurements made with sensor connected to unit and power applied. Sensor voltages are DC volts.

°F	Ohms	Volts	°F	Ohms	Volts	°F	Ohms	Volts	°F	Ohms	Volts
1	82,719	4.46	41	25,391	3.59	81	9,076	2.38	121	3,679	1.34
2	80,142	4.45	42	24,704	3.56	82	8,861	2.35	122	3,602	1.32
3	77,656	4.43	43	24,037	3.53	83	8,651	2.32	123	3,527	1.30
4	75,255	4.41	44	23,391	3.50	84	8,447	2.29	124	3,454	1.28
5	72,937	4.40	45	22,764	3.47	85	8,249	2.26	125	3,382	1.26
6	70,698	4.38	46	22,156	3.45	86	8,056	2.23	126	3,312	1.24
7	68,535	4.36	47	21,566	3.42	87	7,867	2.20	127	3,244	1.22
8	66,447	4.35	48	20,993	3.39	88	7,684	2.17	128	3,177	1.21
9	64,428	4.33	49	20,438	3.36	89	7,506	2.14	129	3,112	1.19
10	62,479	4.31	50	19,900	3.33	90	7,333	2.12	130	3,049	1.17
11	60,595	4.29	51	19,377	3.30	91	7,164	2.09	131	2,987	1.15
12	58,774	4.27	52	18,870	3.27	92	6,999	2.06	132	2,926	1.13
13	57,014	4.25	53	18,377	3.24	93	6,839	2.03	133	2,867	1.11
14	55,313	4.23	54	17,899	3.21	94	6,683	2.00	134	2,809	1.10
15	53,669	4.21	55	17,435	3.18	95	6,530	1.98	135	2,752	1.08
16	52,078	4.19	56	16,985	3.15	96	6,382	1.95	136	2,697	1.06
17	50,541	4.17	57	16,548	3.12	97	6,238	1.92	137	2,643	1.05
18	49,054	4.15	58	16,123	3.09	98	6,097	1.89	138	2,591	1.03
19	47,616	4.13	59	15,711	3.06	99	5,960	1.87	139	2,539	1.01
20	46,225	4.11	60	15,310	3.02	100	5,827	1.84	140	2,489	1.00
21	44,879	4.09	61	14,921	2.99	101	5,697	1.81	141	2,440	0.98
22	43,577	4.07	62	14,543	2.96	102	5,570	1.79	142	2,392	0.97
23	42,318	4.04	63	14,176	2.93	103	5,446	1.76	143	2,345	0.95
24	41,099	4.02	64	13,820	2.90	104	5,326	1.74	144	2,299	0.93
25	39,919	4.00	65	13,473	2.87	105	5,208	1.71	145	2,254	0.92
26	38,777	3.97	66	13,136	2.84	106	5,094	1.69	146	2,210	0.90
27	37,671	3.95	67	12,809	2.81	107	4,982	1.66	147	2,167	0.89
28	36,601	3.93	68	12,491	2.78	108	4,873	1.64	148	2,125	0.88
29	35,565	3.90	69	12,182	2.75	109	4,767	1.61	149	2,084	0.86
30	34,561	3.88	70	11,882	2.72	110	4,664	1.59	150	2,044	0.85
31	33,590	3.85	71	11,589	2.68	111	4,563	1.57	151	2,005	0.84
32	32,648	3.83	72	11,305	2.65	112	4,464	1.54	152	1,966	0.82
33	31,737	3.80	73	11,029	2.62	113	4,368	1.52	153	1,929	0.81
34	30,853	3.78	74	10,761	2.59	114	4,274	1.50	154	1,892	0.80
35	29,998	3.75	75	10,500	2.56	115	4,183	1.47	155	1,856	0.78
36	29,169	3.72	76	10,246	2.53	116	4,094	1.45	156	1,821	0.77
37	28,365	3.70	77	9,999	2.50	117	4,007	1.43	157	1,787	0.76
38	27,587	3.67	78	9,758	2.47	118	3,922	1.41	158	1,753	0.75
39	26,832	3.64	79	9,525	2.44	119	3,839	1.39	159	1,720	0.73
40	26,100	3.61	80	9,297	2.41	120	3,758	1.37	160	1,688	0.72