

PV BATTERY CHARGE REGULATOR WITH TIMER AND LOW VOLTAGE DISCONNECT (LVD) 12, 24, 48 VOLTS DC • 15-22 AMP

15 AMP PBRT

15 AMP PV BATTERY CHARGE REGULATOR WITH TIMER, LVD PBRT 12-15, 24-15, 48-15



SPECIFICATIONS	
Rated Input Current-	15 Amps
Surge Rating-	30 Amps for 20 Sec
Voltage Available-	12, 24, 48 VDC
Load Current-	15 Amps
LVD (12 Vdc) -	11.7 Vdc
LVD (24 Vdc) -	23.4 Vdc
LVD (48 Vdc) -	46.8 Vdc
Mounting Holes-	Four
Hole Diameter-	3/16 in
Weight-	1.5 lbs (0.68 kgs)
Dimensions (inches)-	7 x 4.75 x 1.75

22 AMP PBRT

22 AMP PV BATTERY CHARGE REGULATOR WITH TIMER, LVD PBRT 12-22



SPECIFICATIONS	
Rated Input Current-	22 Amps
Surge Rating-	44 Amps for 20 Sec
Voltage Available-	12 VDC
Load Current-	15 Amps
LVD (12 Vdc) -	11.7 Vdc
Mounting Holes-	Four
Hole Diameter-	3/16 in
Weight-	1.5 lbs (0.68 kgs)
Dimensions (inches)-	7 x 4.75 x 1.75

PBRT Charge Regulator Selection Guide

Nominal System Voltage	Rated Array Power	PBRT Model #	Rated Input Current
12 Vdc	255 Wp	PBRT 12-15	15 Amps
24 Vdc	375 Wp	PBRT 12-22	22 Amps
24 Vdc	510 Wp	PBRT 24-15	15 Amps
48 Vdc	765 Wp	PBRT 48-15	15 Amps

Vdc - Volts Direct Current, Wp -Peak Watts

Instructions for PBRT Charge Regulator Selection Guide on back of page.

Battery Type Chart

LA	Lead Acid	A	Absolyte
D	Delco	PL	Pure Lead
C	Concord, Deka	S	Sonnenschine

FEATURES

TIMING FEATURE

The PBRT Charge Regulator uses the input current of the PV array as a light sensor. If darkness is detected, the PBRT turns on the load for the desired length of time. A programmable dip-switch allows for incremental load timing from 3.75 minutes up to 15 hours, 56 minutes. Ideal for use in timed photovoltaic applications such as street lights, billboard lighting and bus shelter lighting.

DC LOAD CONTROLLER WITH LOW VOLTAGE DISCONNECT

The PBRT Charge Regulator incorporates a DC load controller that can automatically detect low battery voltage and disconnect power to the DC load. After the battery bank has sufficiently recharged, the PBRT automatically reconnects the DC load. This feature can significantly increase life of the battery bank. Custom low-voltage disconnect settings available on request.

PATENTED PARALLEL SWITCHING SHUNT

When the maximum charging voltage is reached, the patented parallel switch (U.S. Patent # 4661758) automatically shunts the incoming PV array current.

PULSE WIDTH MODULATION

Automatically adjusting to the load requirements and battery age, Pulse Width Modulation brings the battery up to maximum charge without trickle charging. High charge rates maintain current density across the surface of the plates, maximizing battery life.

TRANSIENT SURGE PROTECTION

Surge rating of twice the rated input current for 20 seconds. Solid state transient absorbing avalanche diodes protect the regulators from lightning induced surges and inductive load spikes.

TEMPERATURE COMPENSATED

To extend battery life and prevent stratification, the PBRT Regulators automatically adjust the maximum charge voltage relative to the temperature of the batteries.

BATTERY CAPACITY METER

BATTERY CAPACITY METER

BCM 12, 24, 36, 48



SPECIFICATIONS

Voltage Available-	12, 24, 36, 48 VDC
Cable Length-	60 in (152.4 cm)
Weight-	0.375 lb (0.170 kg)
Dimensions (inches)-	2.0 x 4.0 x 0.75
Accuracy-	± 0.05 Vdc (12 V dc)

The four function BCM may be used in conjunction with the PBRT Battery Charge Regulator or as a separate unit. Utilizing 13 LEDs, the BCM indicates Battery Capacity, Float, Equalize and Low Voltage.

Indicates Battery Capacity, Float, Equalize, Low Voltage

PBRT Wiring Diagram

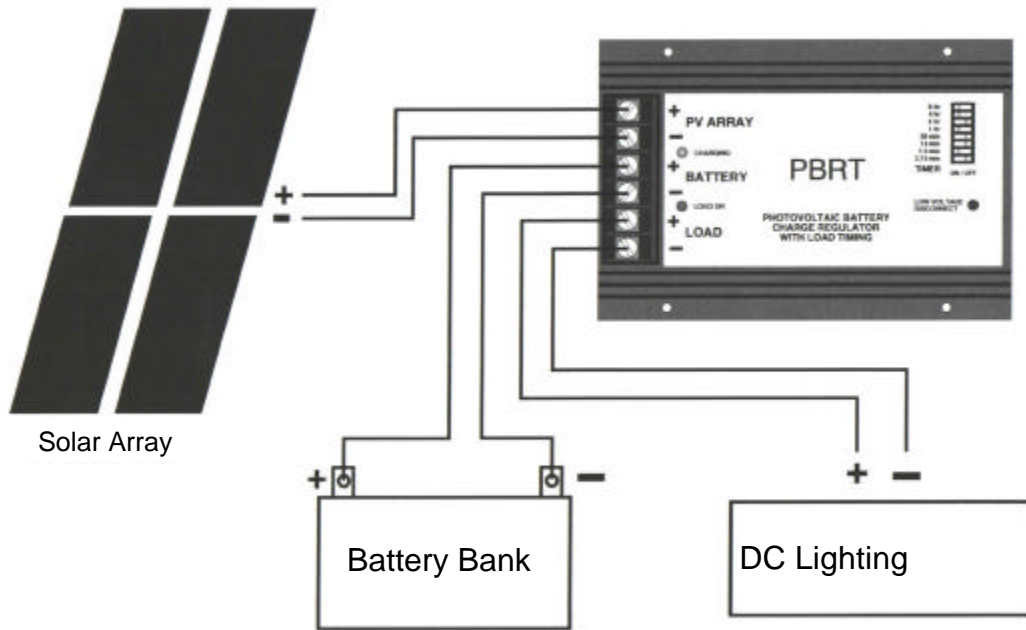

PBRT Selection Guide Instructions

1. **Determine the nominal operating voltage of your PV array and battery system** (this may be dependent on your application, system size or inverter input requirements). We recommend increasing your system operating voltage to 24 Vdc when your PV array is larger than 1 kWp, or 48 Vdc when your PV array is larger than 2 kWp.
2. **Select the rated array power** to the left of the nominal system voltage that is equal to or less than your actual array power rating.
3. **The PBRT model listed to the right is recommended for use with your system.** If you plan to expand your photovoltaic array in the future, you should select a PBRT model with a higher current rating than the one that meets your current requirements.
4. **When ordering your PBRT, please indicate the battery chemistry** you have selected for your system. ETA Charge Regulators are factory set to operate with specific battery types, thereby ensuring that your battery life is maximized. See Battery Type Chart on front page. (Custom settings available on request).

* Note: ETA manufactures custom PBRTs for different system requirements.

Warranty Information

Should a defect appear in a **properly maintained ETA manufactured** product, ETA Engineering, Inc. at its option will promptly exchange such for a period of five years, unless the specific product carries a longer warranty. For non-ETA manufactured products, the OEM warranty will be passed through as appropriate.

All products **shall** be returned at the owner's expense to the location so specified. Labor charges, insurance fees, if any, are not included in this guarantee and are to be paid by the owner under this guarantee.

This guarantee is void as to any equipment which has been subject to misuse, accident, "acts of God", negligent damage, damaged in transit or damaged in handling as determined by the **ETA QC** department.

This guarantee is in lieu of all other guarantees expressed or implied, and all warranties expressed or implied, including the warranty of merchantability, fitness for purpose sold, description, and all other obligations and liability on the Corporation's part and the Corporation neither assumes nor authorizes any other person to assume for the Corporation any other liability in connection with the sale of our products. The corporation shall not be liable by virtue of this guarantee or otherwise for special or consequential damage to any persons or property or other equipment or for delay in performance of this warranty.

Installation Instructions

When installing your PBRT charge regulator, mount or locate the unit in or near the battery storage location. This will allow the charge regulator to approximate the temperature of the battery system and ensures that temperature compensated charging takes place.

Wiring Instructions:

1. Ensure that the photovoltaic array is properly wired to match the nominal operating voltage of the regulator and battery system (usually 12, 24 or 48 Vdc). Proper wiring diagrams for PV module/array can be obtained from the manufacturer or system designer. Identify the positive and negative leads of the PV array prior to connecting to the charge regulator.
2. Connect the battery leads to the terminal blocks on the PBRT charge regulator labeled "Battery", also ensuring that the polarity of the battery leads are matched to the polarity of the terminal blocks.
3. Due to the regulator's very high efficiency, it will be destroyed if hooked-up improperly. Connect the PV array input leads to the terminal blocks on the PBRT charge regulator labeled "PV Array", ensuring that the polarity of the input leads are matched to the polarity of the terminal blocks (**positive to positive, negative to negative**).
4. Connect the negative and positive leads of the load to the terminal block labeled "Load", ensuring that the polarity of the load leads are matched to the polarity of the terminal blocks (**positive to positive, negative to negative**).

Note: The regulators are protected if the battery connections are removed and the PV array remains connected. (The regulator will rapidly turn on and off without).

Installation and Operation Notes:

1. Bare wire connections under the PBRT charge regulator terminal blocks are acceptable. PBRT models accept up to two #10 gauge bare wire inputs under each terminal clamp.
2. When the battery reaches the pre-set maximum voltage level at a given temperature, the PV module input will be shorted ("shunted") to a value near zero volts. The battery voltage will gradually drop back to a lower voltage, at which point the regulator will release the PV input, and charging will resume. At this time, the regulator input (module voltage) will be about one-half volt higher than the regulator output (battery voltage).
3. When the battery reaches the pre-set low voltage level at a given temperature, the regulator shuts the load down until the battery voltage is restored to one volt above the low voltage level.
4. The "Shunt" and "LVD" voltage level are factory set. No field adjustments are required.
5. The settings of the programmable dip switches determine the operational time of the load. Time adds together when multiple switches are placed in the on position.